



Mechanical chucks  
Testate meccaniche





SINCE  
'74

# RE-SOLVING

MACHINING LAMINATES REQUIRES AUTOMATED PROCESSES, AND AUTOMATION REQUIRES A RANGE OF EQUIPMENT DESIGNED TO OPTIMISE PRODUCTION AND REDUCE TIMES, COSTS AND THE RISK OF ERROR. IF YOU WANT TO FIND ALL THIS IN ONE BRAND NAME ONLY, ASK AND ASK AGAIN. THE ANSWER WILL ALWAYS BE: **RE**.

LA LAVORAZIONE DEI LAMINATI RICHIEDE PROCESSI AUTOMATIZZATI. L'AUTOMAZIONE RICHIEDE EQUIPAGGIAMENTI DIVERSI, TUTTI MIRATI A OTTIMIZZARE LA PRODUZIONE, RIDUCENDO TEMPI, COSTI E RISCHI DI ERRORE. SE VUOI TROVARE TUTTO IN UN NOME SOLO, CHIEDI E RICHIEDI. IN MOLTI TI DIRANNO: **RE**.



Mechanical chucks are used in shaftless applications to guarantee a perfect control on the reel in unwinding and rewinding stations.

The mechanical chucks are usually used when:

- the reel is too heavy to be supported by an expanding shaft,
- the machine is very wide,
- the diameter of the reel core is often different.

Re chucks are designed and produced with sturdy materials and comply with high quality standards to ensure you elevated performances, long-life span and almost zero maintenance costs also in difficult working conditions.

We offer our clients a wide range of chucks:

- classic TM/A - TM/B axial thrust chucks with keys,
- Rotogrip rotating chucks,
- pneumatic-mechanical chucks MX16.3 - Pneumogrip).

All available both in mono and double diameter versions and in various dimensions accordingly to the application.

Le testate meccaniche sono utilizzate in applicazioni shaftless per garantire un perfetto controllo delle bobine in fase di svolgimento e avvolgimento.

Vengono solitamente utilizzate nei seguenti casi:

- peso della bobina troppo elevato per essere supportato da un albero espansibile,
- ampia larghezza della macchina,
- diametro delle anime della bobina spesso differenti.

Le testate Re sono progettate e realizzate utilizzando materiali resistenti, e rispondono ad elevati standard qualitativi per farvi ottenere performance elevate, durata e manutenzione pressochè nulla anche in condizioni di lavoro non ottimali.

Offriamo ai nostri clienti una vasta gamma di testate:

- le classiche TM/A - TM/B a spinta assiale con chiavette,
- le Rotogrip a rotazione,
- le pneumo-meccaniche MX16.3 e PNEUMOGRIIP.

Tutte disponibili mono e bidiametrali in diverse dimensioni.

This catalogue information is correct at date of publication, but is subject to change without prior notification, or as required by Re S.p.A. Technical data are also illustrative and for product selection, while designing the application we recommend you to get an opinion from our sales-engineer, in order to select the most suitable size.

I dati del presente catalogo sono ritenuti corretti al momento della pubblicazione, ciò non implica responsabilità da parte della Re S.p.A. per eventuali variazioni intervenute successivamente. I suddetti dati sono inoltre orientativi alla scelta del prodotto, in fase di progettazione dell'applicazione, consultare i nostri tecnici commerciali in modo da selezionare il modello più idoneo.



# ROTOGRIP

ROTATION CHUCKS / TESTATE A ROTAZIONE



## ROTOGRIP

monodiametral  
monodiametrale

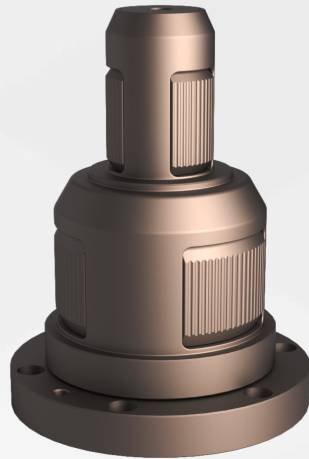

## ROTOGRIP

bidiametral  
bidiametrale

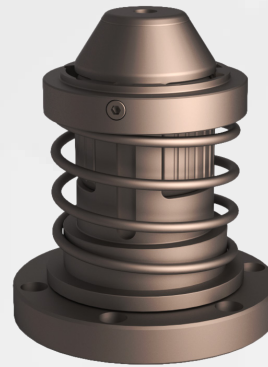

## ROTOGRIP

with spring  
con molla



## ROTOGRIP

with ejection flange  
con flangia di espulsione

The Rotogrip rotation core chucks use the torque produced by the braking force and the opposite web tension (coupled with a brake or motor) to expand the sector elements in order to block and centre automatically the roll core.

The sector elements, with a wide contact surface, ensure maximum control of the reel and reduce damages to the cardboard cores, which can be therefore used again. Flexibility is another important characteristic of Rotogrip chucks: depending on customer application are available different dimensions, mono or double bidiameter, for cores from 3" to 12", with spring or ejection flange for pneumatic pistons; with knurled or smooth sectors for cores made of materials other than cardboard.

For these characteristics of sturdiness, flexibility, and ease of installation the Rotogrip chuck is widely used with reel of big size and weight, such as in corrugated cardboard production sector.

Le testate Rotogrip sfruttano il momento torcente generato dall'azione frenante ed il tiro della bobina, solidale ad un freno o motore, per far espandere i tegoli e bloccarne l'anima.

Il centraggio della bobina avviene automaticamente, mentre i settori, con ampia superficie, garantiscono il massimo controllo della bobina e assenza di danneggiamento delle anime che potranno così essere riutilizzate.

Altra caratteristica importante delle testate Rotogrip è la flessibilità: a seconda dell'applicazione possono essere infatti realizzate nella versione monodiametrale o bidiametrale per anime da 3" a 12", con molla o con flangia di espulsione per pistoni pneumatici e con settori zigrinati o lisci per il serraggio di anime di materiali differenti.

Per queste sue caratteristiche di robustezza, flessibilità e semplicità di installazione la testata Rotogrip viene solitamente utilizzata in settori che utilizzano bobine di grandi dimensioni e peso come nella produzione di cartone ondulato.



# ROTOGRIP

## TECHNICAL DRAWINGS DISEGNI TECNICI

### MONODIAMETRAL MONODIAMETRALE

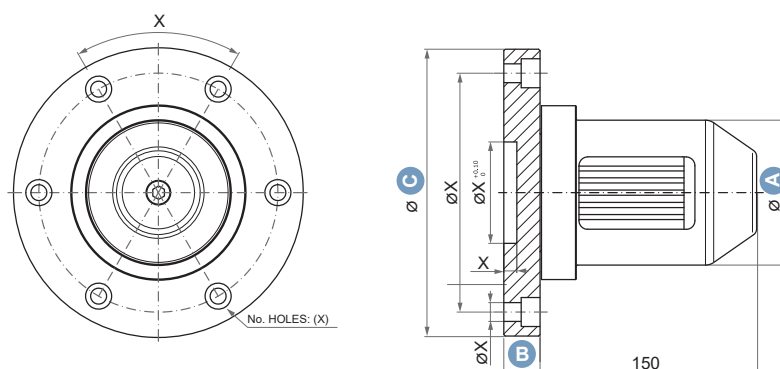

Inside core $\varnothing$ $\varnothing$ interno anima Inches	$\varnothing$ A mm	B mm	$\varnothing$ C mm	X mm	Min expansion Espansione max mm	Max expansion Espansione max mm	Max load Portata max N	Transmissible torque Coppia trasmissibile Nm
3"	74,5	20	176	your choice	75,5	85,5	18000	1500
$\varnothing$ 100	98	30	198	your choice	99	109	45000	2500
4"	100	30	198	your choice	101	111	45000	2500
5"	126	30	216	your choice	126	136	45000	2500
6"	151	30	216	your choice	151	161	110000	5000
12"	302	30	220	your choice	303	313	110000	16000

All data have to be considered for single chuck.  
Tutti i dati sono da considerarsi per singola testata.

### BIDIAMETRAL BIDIAMETRALE

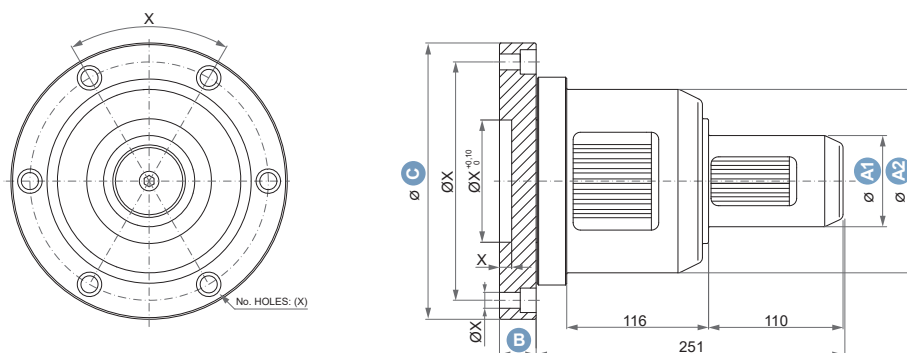

Inside core $\varnothing$ $\varnothing$ interno anima Inches	$\varnothing$ A1/A2 mm	B mm	$\varnothing$ C mm	X mm	Min expansion Espansione min mm	Max expansion Espansione max mm	Max load Portata max N	Transmissible torque Coppia trasmissibile Nm
3/4"	74,5/100	25	200	your choice	75,5/101	85,5/111	18000/45000	1150/2500
3/6"	74,5/150	30	216	your choice	75,5/151	85,5/161	18000/110000	1150/5000
4/6"	100/150	30	216	your choice	101/151	111/161	45000/110000	2500/5000

All data have to be considered for single chuck.  
Tutti i dati sono da considerarsi per singola testata.



# ROTOGRIP

## TECHNICAL DRAWINGS DISEGNI TECNICI

### ROTOGRIP WITH EJECTION FLANGE ROTOGRIP CON MOLLA

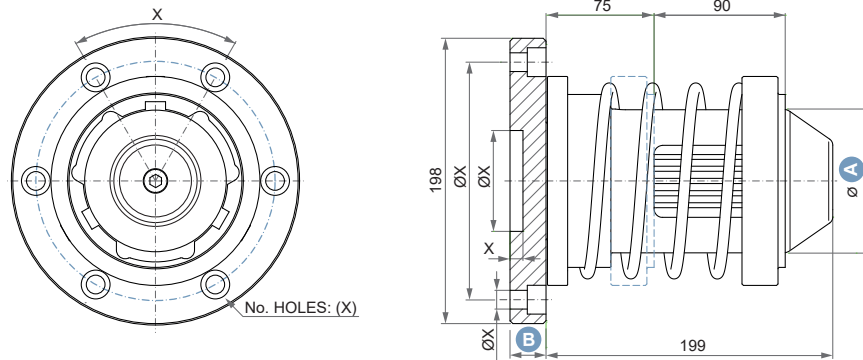

Inside core $\varnothing$ $\varnothing$ interno anima	$\varnothing$ A mm	B mm	X mm	Min expansion Espansione max mm	Max expansion Espansione max mm	Max load Portata max N	Transmissible torque Coppia trasmissibile Nm
3"	74,5	20	your choice	75,5	85,5	18000	1500
$\varnothing$ 100 mm	98	30	your choice	99	109	45000	2500
4"	100	30	your choice	101	111	45000	2500

All data have to be considered for single chuck.  
Tutti i dati sono da considerarsi per singola testata.

### ROTOGRIP WITH FLANGE ROTOGRIP CON FLANGIA

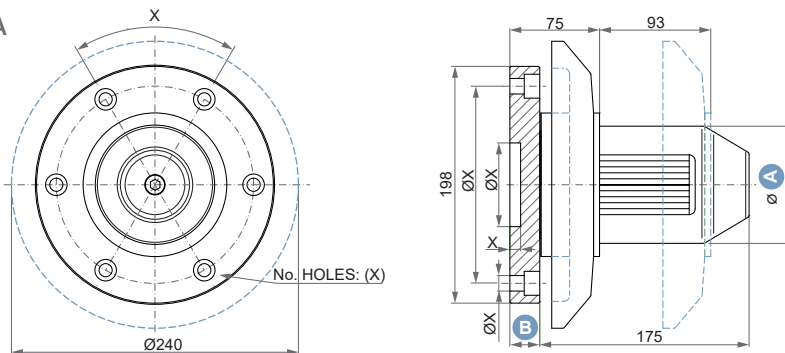

Inside core $\varnothing$ $\varnothing$ interno anima	$\varnothing$ A mm	B mm	X mm	Min expansion Espansione min mm	Max expansion Espansione max mm	Max load Portata max N	Transmissible torque Coppia trasmissibile Nm
3"	74,5	20	your choice	75,5	85,5	18000	1500
$\varnothing$ 100 mm	90	30	your choice	99	109	45000	2500
4"	100	30	your choice	101	111	45000	2500

All data have to be considered for single chuck.  
Tutti i dati sono da considerarsi per singola testata.



# TM/A - TM/B

MECHANICAL CHUCKS / TESTATE MECCANICHE



TM/A

monodiametral  
monodiametrale



TM/B

bidiametral  
bidiametrale

## TM/A with central bore con foro centrale

For the centering of the reel with photoelectric sensor  
Per il centraggio della bobina con fotocellula

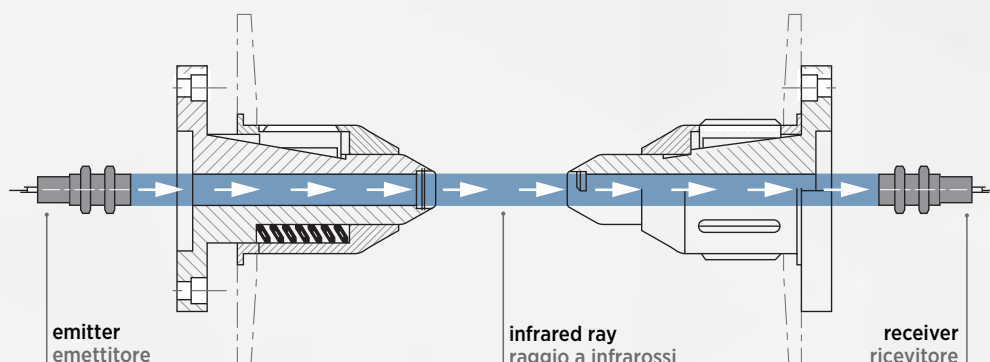

The TM axial thrust mechanical core chucks are provided with a spring system which, using the axial thrust when introduced inside the reel core, expand a series of keys that guarantee the right grip of the reel.

The TM chucks provide the best quality to price ratio to clamp reels of any material.

Thanks to their flexibility, they can be installed on any kind of application as they are available in mono and double diameter versions, for load up to 300.000 N (the pair) and in special versions: with central bore for centering of the reel with photoelectric sensor, or with ejection flange.

Le testate meccaniche TM a spinta assiale, sono dotate di un sistema di molle che, sfruttando la spinta assiale nel momento di inserimento delle anime, fanno espandere una serie di chiavette che garantiscono un corretto serraggio della bobina.

Le testate TM rappresentano il miglior compromesso qualità-prezzo per il serraggio delle bobine di qualsiasi materiale.

Grazie alla loro flessibilità, possono essere installate su tutte le tipologie di applicazioni: sono disponibili, infatti, in versione monodiametrale e bidiametrale, per carichi fino a 300.000 N la coppia e in versioni speciali con foro passante per il passaggio della fotocellula per il centraggio, o con flangia di espulsione.



# TM/A - TM/B MECHANICAL CHUCKS

## TECHNICAL DRAWINGS DISEGNI TECNICI

### TM/A MONODIAMETRAL TM/A MONODIAMETRALE

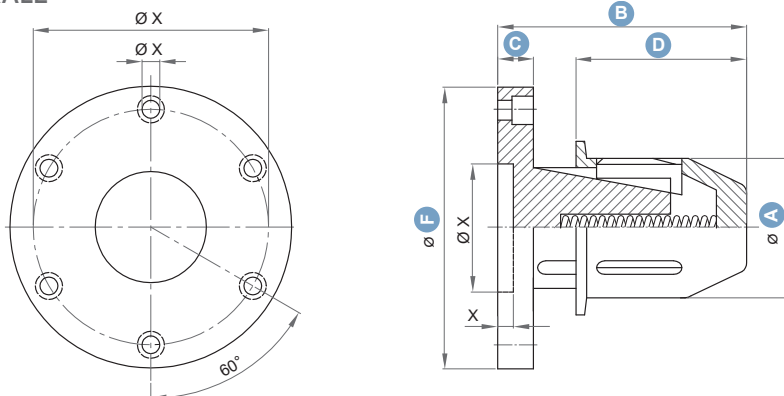

Inside core $\varnothing$ $\varnothing$ interno anima Inches	$\varnothing$ A mm	B mm	C mm	D mm	$\varnothing$ F mm	X mm	Max load Portata max N	Transmissible torque Coppia trasmissibile Nm
3"	74,5	175	25	120	168	your choice	12000	250
4"	98	175	25	120	195	your choice	27000	1100
5"	125	165	30	105	195	your choice	50000	2500
6"	148	165	30	105	216	your choice	75000	3000
12"	301	165	30	105	415	your choice	150000	18000

All data have to be considered for single chuck.  
Tutti i dati sono da considerarsi per singola testata.

### TM/B BIDIAMETRAL TM/B BIDIAMETRALE

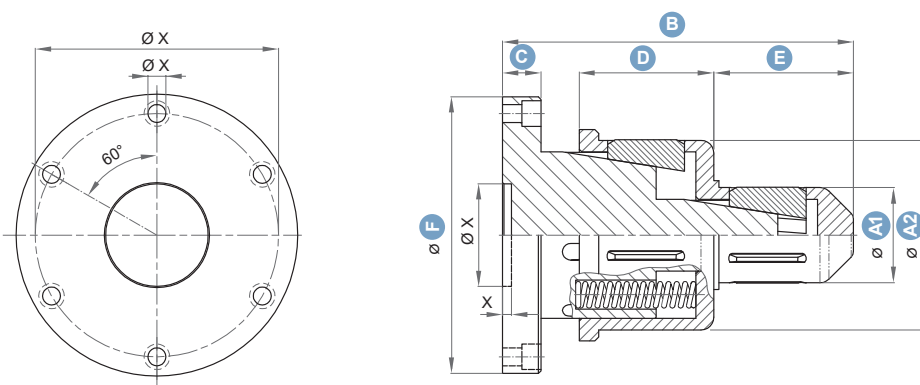

Inside core $\varnothing$ $\varnothing$ interno anima	$\varnothing$ A1/A2 mm	B mm	C mm	D mm	E mm	$\varnothing$ F mm	X mm	Max load Portata max N	Transmissible torque Coppia trasmissibile Nm
3/4"	74,5/98	238	25	85	98	195	your choice	7500/25000	250/1100
3/6"	74,5/148	274	30	105	109	216	your choice	15000/75000	250/3000
4/6"	98/148	268	30	104	104	216	your choice	27000/75000	1100/3000

All data have to be considered for single chuck.  
Tutti i dati sono da considerarsi per singola testata.





# MX 16.3 - PNEUMOGRIP

PNEUMO-MECHANICAL CHUCKS / TESTATE PNEUMO-MECCANICHE



The MX 16.3 core chuck is equipped with a pneumo-mechanical mechanism which, using air pressure, expands or releases the keys for a safe and good fixing of the reel core.

Specifically designed for converting sector, the MX 16.3 chuck is compact and robust and it guarantees safety for the operator, reliability on the reel control and no maintenance.

The basic version fits cores with 70 mm or 3" of diameter, whereas the AX diameter adaptors fit rolls with different dimensions: 4", 5" and 6".

It can support reels up to 20.000 N (the pair).

The Pneumogrip core chuck features a pneumo-mechanical mechanism that, using air pressure, expands the sectors, for a safe and perfect fixing of the reels. It guarantees cleaning, safety for the operator, strength and flexibility.

It can be made, depending on the application needed, in mono or double diameter version and also with adaptors, for cores from 70 mm to 12" of diameter and for high load up to 40.000 N. For these characteristics of sturdiness and flexibility the Pneumogrip chuck is usually used in industries that use reels of great dimensions and weight, as in the corrugated cardboard production sector.

La testata MX 16.3 è dotata di un meccanismo pneumo-meccanico che, sfruttando la pressione dell'aria, espande o rilascia le chiavette per un sicuro e ottimale serraggio delle bobine.

Specifica per il settore del converting, la testata MX 16.3 è compatta e robusta; garantisce sicurezza per l'operatore, affidabilità nel controllo della bobina e assenza di manutenzione.

La versione base permette l'utilizzo con anime di diametro 70 mm e 3", ma gli adattatori AX ne permettono l'utilizzo anche con anime di dimensioni differenti: 4", 5" e 6" e con portate fino a 20.000 N (la coppia).

La testata Pneumogrip è dotata di un meccanismo pneumo-meccanico che, sfruttando la pressione dell'aria, permette l'espansione dei tegoli per un sicuro ed ottimale serraggio delle bobine.

Garantisce pulizia, sicurezza per l'operatore, resistenza e flessibilità. Essa può infatti essere realizzata, a seconda dell'applicazione necessaria, in versione monodiametrica o bidiametrica, o con adattatori, per diametri da 70 mm a 12" e per carichi elevati fino a 40.000 N.

Per queste sue caratteristiche di robustezza e flessibilità, la testata Pneumogrip viene solitamente utilizzata in settori che utilizzano bobine di grandi dimensioni e peso, come nella produzione di cartone ondulato.



# MX 16.3 - AX

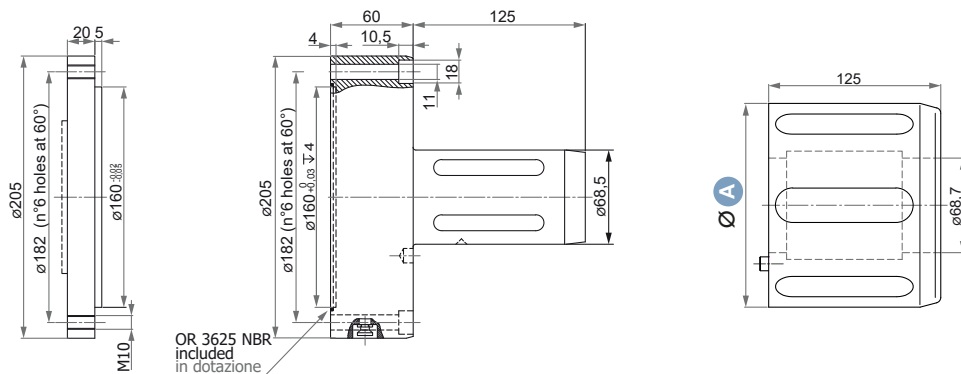

	Inside core $\varnothing$ $\varnothing$ interno anima	$\varnothing$ A mm	Min air pressure Pressione aria min bar	Max expansion Espansione max mm	Max load Portata max N	Transmissible torque Coppia trasmissibile Nm
<b>MX 16.3</b>	70 - 76,2 (3")	-	5	80	12500	450
<b>AX4</b>	101,6 (4")	98,5	5	104	12500	600
<b>AX5</b>	127 (5")	125	5	130	12500	650
<b>AX6</b>	152,4 (6")	148	5	155	12500	800

# PNEUMOGRIP

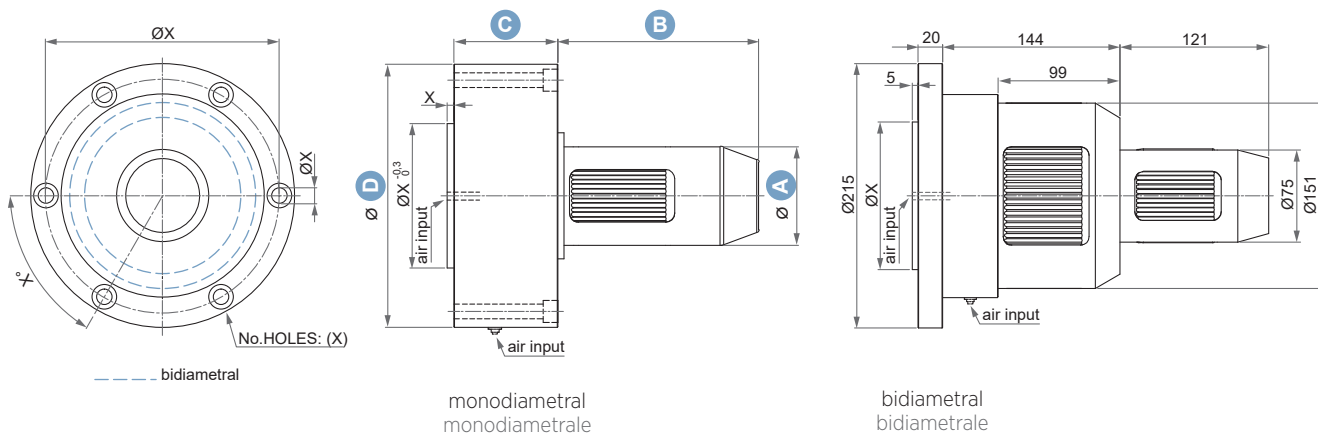

Inside core $\varnothing$ $\varnothing$ interno anima Inches	$\varnothing$ A mm	B mm	C mm	$\varnothing$ D mm	X mm	Max expansion Espansione max mm	Max load Portata max N	Transmissible torque Coppia trasmissibile Nm
<b>70/3"</b>	69	132	88	200	no. 6 $\varnothing$ 11 mm	83	15000	900
<b>3"</b>	75	153	79	200	your choice	85	20000	1000
<b>3/6"</b>	-	-	-	-	your choice	85/161	20000/30000	1000/1200

Inside core $\varnothing$ $\varnothing$ interno anima Inches	For chuck per testata inches	$\varnothing$ E mm	F mm	G mm	Max expansion Espansione max mm
<b>4"</b>	<b>3"</b>	101	122	131,5	111
<b>6"</b>	<b>3"</b>	151	172	142	161
<b>100/4"</b>	<b>70/3"</b>	99	120	132	109
<b>150/6"</b>	<b>70/3"</b>	149	170	132	163

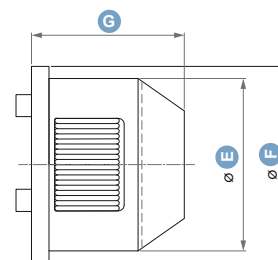

All data have to be considered for single chuck.  
Tutti i dati sono da considerarsi per singola testata.



# APPLICATIONS

APPLICAZIONI



Rotogrip with flange on unwinder

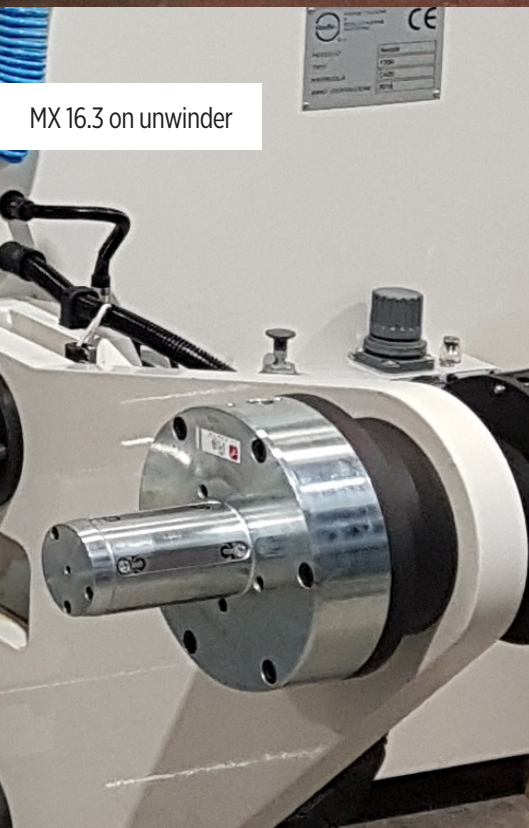

MX 16.3 on unwinder

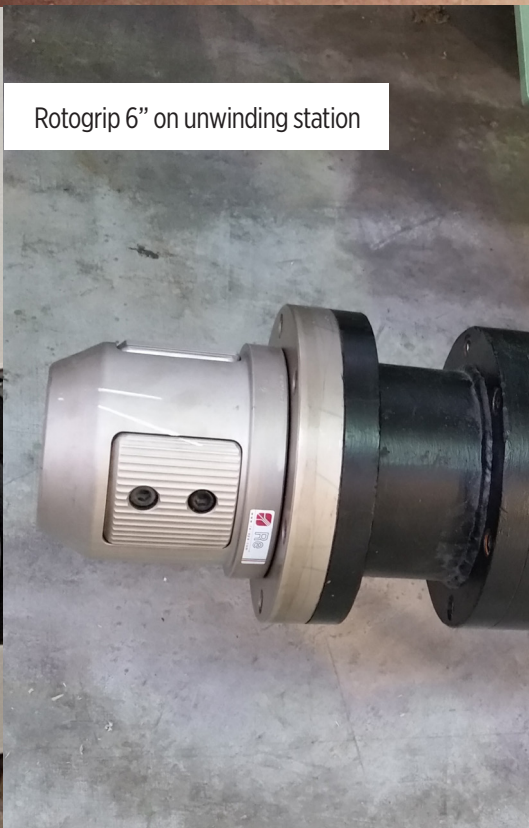

Rotogrip 6" on unwinding station

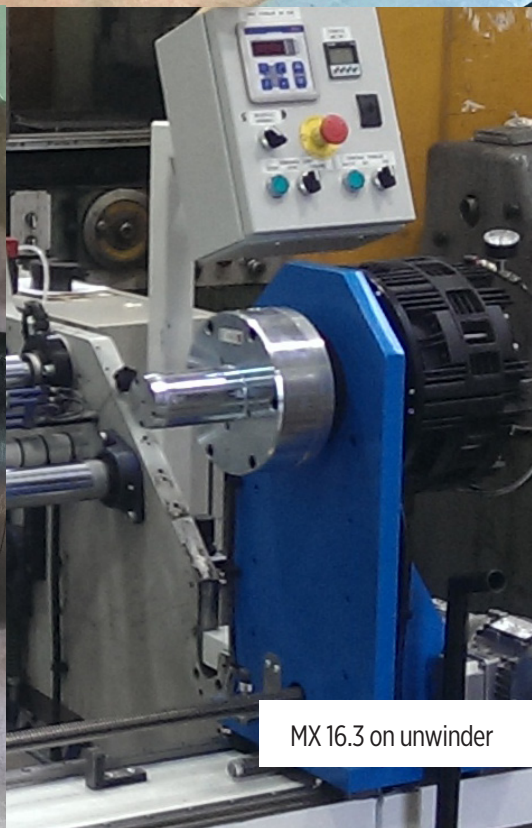

MX 16.3 on unwinder

[WWW.RE-SPA.COM](http://WWW.RE-SPA.COM)



**Registered office**  
viale E. Caldara, 40  
20122 Milano Italy

**Headquarters**  
Via Firenze, 3  
20060 Bussero (MI) Italy

T +39 02 952430.200  
F +39 02 95038986  
[info@re-spa.com](mailto:info@re-spa.com)